



CABINETCORP™

**BY CABINET PROFESSIONALS,
FOR CABINET PROFESSIONALS**



**Designer quality cabinets,
flooring, and closet solutions
without the designer price tag**

With more than 30 years of experience, CabinetCorp is the proven industry leader in the manufacture of kitchen and bathroom cabinets at below-market pricing.

With a large variety of cabinet finishes, accessories & solutions, let our team help you customize and bring your dream space to life. We can assist you with everything from measuring all the way to the installation, all with exceptional customer service!



Cabinets



Closets



Flooring



Free Design Services!

When working with CabinetCorp, you will be partnered with one of our amazing kitchen designers. You will receive a certified 2020/3D kitchen rendering, FREE. We will show you how your newly remodeled kitchen will look before purchasing.



Customizable to fit your design

Framed vs. Frameless Cabinets?

Framed cabinets are typically the standard you would see in most American homes. The framed construction uses a face-frame that is attached to the cabinet box, adding additional sturdiness to the cabinet box. With the presence of rails and stiles on the face frame, they make for easier installation and door/drawer adjustments.

Frameless cabinets, often referred to as "fullaccess" or European style cabinets, have been steadily gaining popularity in the United States. Unlike framed cabinetry, frameless cabinets do not utilize a face-frame attached to the cabinet box but instead relies on a thicker box and support rails for strength. With the absence of a face-frame, full-accessibility to the cabinet offers more storage solutions when compared to framed cabinetry.

At CabinetCorp, we offer a variety of full-overlay door styles and finishes for both our framed and frameless cabinetry. While our framed cabinets lean more towards a traditional design aesthetic and our frameless is more contemporary, knowing the functionality differences plays a key role when designing your next project.

Contempo Prime FRAMELESS CABINETS



Traditional Prime FRAMED CABINETS

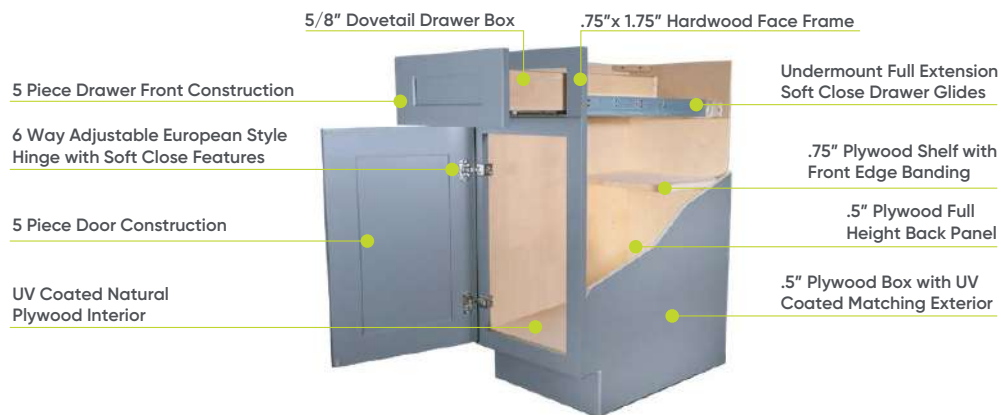

Our best-selling cabinet styles



Cambridge Antique White



Cambridge Sable



Tacoma White



Shaker Gray



Shaker Dusk



Shaker Antique White



Shaker White



Shaker Charcoal Gray

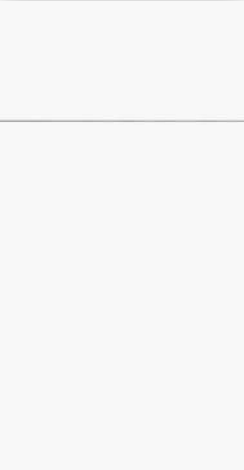

Palena Gloss White



Tempo White Prairie



Tempo Dark Wilderness



Tempo Grey Wilderness



Cambridge



Antique White

Cambridge

TRADITIONAL PRIME FRAMED CABINETS

- Cabinet with Full Overlay Doors and Drawers
- Under Mount Full Extension Soft Close Drawer Glides
- Concealed European Style Hinges with Soft Close Feature
- Dovetail Drawer Box
- Solid Birch Frame with Solid Birch Center Panel *CS
- Five Piece HDF Door *CAW
- 1/2" Plywood Box with UV Coated Matching Exterior
- 3/4" Plywood Shelf with Front Edge Banding
- UV Coated Natural Interior



Cambridge Antique White



Cambridge Sable



Sable

Tacoma



Tacoma White

Tacoma

TRADITIONAL PRIME FRAMED CABINETS

- Painted Cabinet with Full Overlay Doors and Drawers
- Under Mount Full Extension Soft Close Drawer Glides
- Concealed European Style Hinges with Soft Close Feature
- Dovetail Drawer Box
- Solid Birch Frame with Solid Birch Center Panel
- Five Piece HDF Door
- 1/2" Plywood Box with UV Coated Matching Exterior
- 3/4" Plywood Shelf with Front Edge Banding
- UV Coated Natural Interior



Tacoma White

The bright white transitional Tacoma White door profile produces a modernized look with a beveled raised center panel.



Shaker



Antique White

Shaker

TRADITIONAL PRIME FRAMED CABINETS

- Painted Cabinet with Full Overlay Doors and Drawers
- Under Mount Full Extension Soft Close Drawer Glides
- Concealed European Style Hinges with Soft Close Feature
- Dovetail Drawer Box
- Five Piece HDF Door
- 1/2" Plywood Box with UV Coated Matching Exterior
- 3/4" Plywood Shelf with Front Edge Banding
- UV Coated Natural Interior

**Charcoal Grey is a Stained Cabinet with a Solid Birch Door Frame with Veneered MDF Center Panel*



Shaker Gray



Shaker Dusk



Shaker Antique White



Shaker White



Shaker Charcoal Gray

Palena Gloss White



Gloss White

Palena

GLOSS WHITE FRAMELESS CABINETS

- High Gloss White PET Laminate Engineered Wood Door & Drawer with Seamless Edge Technology & White Melamine Back
- White Grey Linen Thermofused Melamine Carcass with Matching Interior
- Full Depth 18mm Adjustable Shelf with Full Edge Banding
- 18mm Plywood Composite Box
- Hettich Sensys Adjustable 110° Soft-Close Hinges
- Adjustable Black Leg Support Included
- Altamax Full Extension Soft-Close Orion Grey Drawer Box

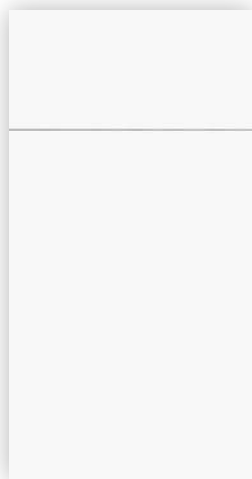

Palena Gloss White

Palena Gloss White delivers a "high-end chic yet functional" look with its high gloss laminate finish & can be used in so many areas of your home.



Gloss White



Tempo

Dark Wilderness

855.216.7970 | www.cabinetcorp.com

Tempo

FRAMELESS CABINETS

- Horizontal Textured Melamine Grey Woodgrain Engineered Wood Door and Drawer Faces
- White Grey Linen Thermofused Melamine Carcass with Matching Interior
- Full Depth 18mm Adjustable Shelf with Full Edge Banding
- 18mm Plywood Composite Box
- Hettich Sensys Adjustable 110° Soft-Close Hinges
- Adjustable Black Leg Support Included
- Altamax Full Extension Soft-Close Orion Grey Drawer Box



Tempo White Prairie



Tempo Dark Wilderness



Tempo Grey Wilderness

Closet Cabinets



Our closet cabinet solutions create the most wanted dream homes. CabinetCorp closet organizers are simple to configure and simple to install. We transform reach-in closets as easily as walk-ins with customizable double-hang cabinets, soft-close drawers and cabinet doors, and tilting shoe shelves. We have closet solutions for every space and every personality. CabinetCorp also offers design services for closets and cabinets.

DOOR STYLES



White



Salt Oak



Espresso



Espresso

WIDTH OPTIONS



18 Inches



24 Inches



30 Inches

Closet Cabinets



Slate Rift



Spiced Mahogany

DOOR STYLES

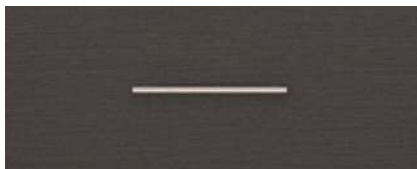

Slate Rift



Spiced Mahogany



White

This Custom Closet System is a built-in, custom storage solution that can be used anywhere in the home.

Transform any closet into an organized, personalized, attractive space. Use it for walk-ins, reach-ins, pantries, linen closets, laundry, mudrooms, and more.

Note: The Cabinet systems are now available for purchase online. Please contact one of our designers to get started on a project



Premium SPC Flooring

CabinetCorp SPC Flooring has the newest generation of floor coverings features:

Enhanced stability, high performance, 100% waterproof, high-density solid core and indentation resistance.

Our flooring can easily be installed on a variety of surfaces including sub-floors, concrete, and existing vinyl flooring. The Unilin Uniclic locking system allows for a seamless, quick, and easy floating installation.

Like our Cabinets, our SPC Flooring is backed with our limited lifetime warranty.

Advance Series

The CabinetCorp Advance Series is not your basic SPC flooring system. It includes premium features such as a 12 mil Scratch Resistant wear layer. The light embossed surface has the look and feel of real wood but includes the comfort features of being 100% waterproof with a limited lifetime warranty. Pre-attached 1mm padding gives you an overall thickness of 5mm flooring.

Luxe Series

The CabinetCorp Luxe Series has all the benefits of the Advance Series but an increased wear layer of 20 mil. The thicker scratch resistant surface adds to the depth of the thicker 4.5 plank. With the sound barrier performance pad attached the thickness of the Luke series plank over all is 5.5 mm. Strong enough for the toughest commercial applications but eco-friendly and safe for any home installation as well.

ADVANCE Series flooring

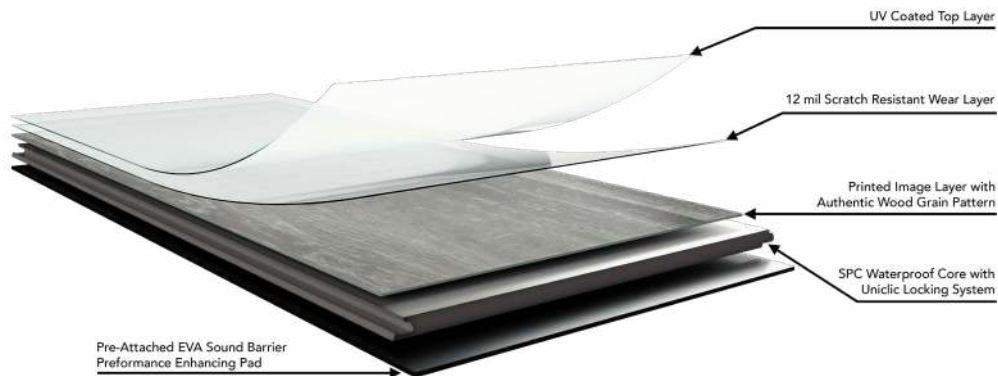

LUXE Series flooring

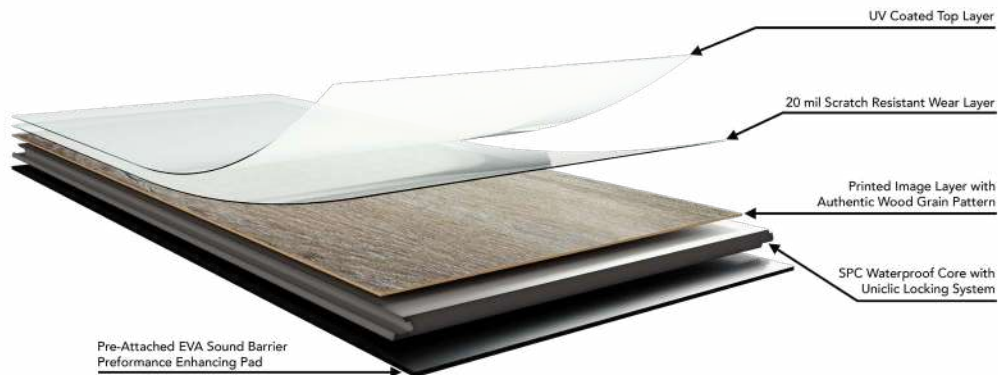

Advance Series

PREMIUM SPC FLOORING

- **Plank Size:** 7"W X 48"L
- **Surface Texture:** Light Embossed
- **Total Thickness:** 4mm + 1
- **Wear Layer:** 12 mil
- **Coverage/Case:** 23.9 SQ FT
- **Installation:** Float & Click with Uniclic Technology
- **Wear Warranty**
 - Residential: Limited Lifetime
 - Light Commercial: 15 Years
- **Floor Score® Rated**



Pallmilla
Sand



Twilight
Grey



Toasted
Pine



Oak
Hill



Java
Hut



Driftwood
Beach



Gray
Dust



Umber
Noir



Luxe Series

PREMIUM SPC FLOORING

- **Plank Size:** 7"W X 48"L
- **Surface Texture:** Light Embossed
- **Total Thickness:** 4.5mm + 1
- **Wear Layer:** 20 mil
- **Coverage/Case:** 21.27 SQ FT
- **Installation:** Float & Click with Uniclic Technology
- **Wear Warranty**
 - Residential: Limited Lifetime
 - Light Commercial: 15 Years
- **Floor Score® Rated**



Hickory
Beige



Narino
Mocha



Smoky
Dove



Acadia
Sand



Ecu
Grey



Burnt
Sienna



Antique
Maple



Sandstone
Oak



Cabinet Style

**Tempo Grey
Wilderness**



Flooring Style

**Luxe
Narino Mocha**





**CONTACT US
TODAY
TO GET STARTED!**

855.216.7970

www.cabinetcorp.com



CABINETCORP™